

GPR-M400 SPECIFICATIONS



TO :

CAT.NO.	PRODUCT NAME
GPR-M400	DC RELAY

	Rev. No	Content	Page	
R e v i s i o n	A	Initial Release(17.07.25)		
	B	1st Revision(19.01.28)		

REMARKS :

ACCEPTABILITY OF SPECIFICATION :

ACCEPTED BY :

ON :

PLEASE CONTACT....

AEC Inc., 1101 Lafayette Street, Elkhart, Indiana 46516, USA. www.aecensors.com

Toll: 888 847 6552, Tel: +1 574 295 6330, Fax: +1 574-293-8013, sales@aecensors.com

LS ELECTRIC Co.,Ltd	DATE	APPROVED BY
	July. 25. 2017	
	PREPARED BY	CHECKED BY

DC RELAY SPECIFICATIONS			LS ELECTRIC Co.,Ltd
MODEL	GPR-M400	PAGE	1/5

1) Type ; GPR-M400

2) Characteristics

2-1. Rating

Frame		GPR-M400		
Pole (P)		1		
Rated insulation voltage (Ui)		DC1000V		
Rated impulse withstand voltage (Uimp)		6kV		
Rated operational voltage (Ue)		DC1000V		
Rating	Continuous current (Ith)		400A	
	Rated operational Current Ie (A)	L/R<1mS	DC1000V	200A
		L/R<1mS	DC800V	250A
		L/R<1mS	DC600V	300A
	Short Time withstand Current	120s		750A
15Min		500A		

2-2. Coil Data

Frame	GPR-M400	
Rated Voltage	12VDC	24VDC
Pick-up Voltage (Initial at 20°C)	Max. 9VDC	Max. 18VDC
Drop-out Voltage (Initial at 20°C)	Min. 1.2VDC	Min. 2.4VDC
Max. Allowable Voltage	15VDC	30VDC
Rated Inrush Current (at 20°C)	4.2A	2.3A
Power Consumption (at 20°C)	4.5W	4.5W
Coil Resistance (at 20°C)	3.4Ω/38.5Ω (±10%)	15.2Ω/157.3Ω (±10%)

2-3. Contact Data

1. Max. Continuous current ; 400A (wire 120mm² X2)
2. Min. Continuous current ; 1A, DC24V
3. Max. switching current (L/R<1mS) ; 3200A at DC450V 1 Cycle (360Cycles/h)
4. Contact Voltage Drop(Initial) ; 0.02V @ 20A 

2-4. Expected Life

1. Electrical Life (L/R<1mS) 
 - (L/R<1mS) ; 200A at DC1000V 1000 Cycles (360Cycles/h)
 - (L/R<1mS) ; 250A at DC800V 3000 Cycles (360Cycles/h)
 - (L/R<1mS) ; 300A at DC600V 3000 Cycles (360Cycles/h)
 - (L/R<1mS) ; 400A at DC200V 30,000 Cycles (360Cycles/h)
(Inrush Current)
2. Reverse Direction Switch-off Life ; 200A at DC300V 1000 Cycles (360Cycles/h)
3. Mechanical ; Min. 200,000ops.(3600 Cycles/h)

DC RELAY SPECIFICATIONS			LS ELECTRIC Co.,Ltd
MODEL	GPR-M400	PAGE	2/5

2-5. Initial Breakdown Voltage

- 1. Between Open Contacts ; 3000Vrms/min (Detection current : 10mA)
- 2. Between Contacts and Coil ; 3000Vrms/min (Detection current : 10mA)
- 3. Between Contacts and Frame ; 3000Vrms/min (Detection current : 10mA)
- 4. Between Coil and Frame ; 3000Vrms/min (Detection current : 10mA)

2-6. Initial Insulation Resistance ; Min. 100MΩ (at DC1000V)
 (Between Coil and Contacts/Between contacts of the same polarity)

2-7. Vibration Resistance

- 1. Functional ; 10 to 1000 Hz @1.0G
 (Detection Time: 10μs, Time of vibration for each X,Y,Z direction : 8 hours)
- 2. Destructive ; 10 to 200Hz in increments of 10 @Min. 4.5G
 (Time of vibration for each X,Y,Z direction : 4 hours)

2-8. Shock Resistance

- 1. Functional ; 196m/s² (20G)
 (Relay On: 11ms half sine, 10μs detection time)
- 2. Destructive ; Min. 490m/s² (50G)
 (Relay On: 9ms half sine wave)

2-9. Operate time (at 20°C, Main Terminal) ; Max. 30ms

2-10. Release time (at 20°C, Main Terminal) ; Max. 10ms

2-11. Tightening torque

- 1. Mounting Hole (M6) ; 6.0 to 8.0 N·m
- 2. Main Terminal (M6) ; 3.5 to 4.5N·m 

2-12. Unit Weight ; Approx. 630g 

3) Operation, Transport, Storage

(Following is the condition of ambient temperature and humidity in case of operation, transport and storage.)

- 3-1. Ambient Temperature ; -40 to 85°C
- 3-2. Ambient Humidity ; 5 to 95%RH
- 3-3. Storage Temperature ; -40 to 85°C
- 3-4. Storage Humidity ; 5 to 95%RH

4) Degrees of protection of enclosed equipment IP ; IP40

5) Short-Circuit Current (FUSE Combination) ; 10KA / 400A FUSE DC1000V (Bussmann, PV-400ANH3)

6) CE, CCC & UL Certificated (IEC60947-4-1, GB14048.4, UL60947-4-1)

DC RELAY SPECIFICATIONS			LS ELECTRIC Co.,Ltd
MODEL	GPR-M400	PAGE	3/5

7) Product Design & Accessories



Connector Information

Housing:MG651026(L)		Terminal:ST730676-3			
Part No.	Wire Range		Tab Thick	Material	
	AWG	mm ²		Thick	Finish
ST30676-3	18-16	AWG5 (CAVS) 0.85-1.25	0.64	0.25	Copper Alloy Pre-Tin

RELAY	PICTURE	COMPONENTS
GPR-M400		STANDARD CONNECTOR 1EA FLANGE BOLT M6-9 2EA

8) Dimension

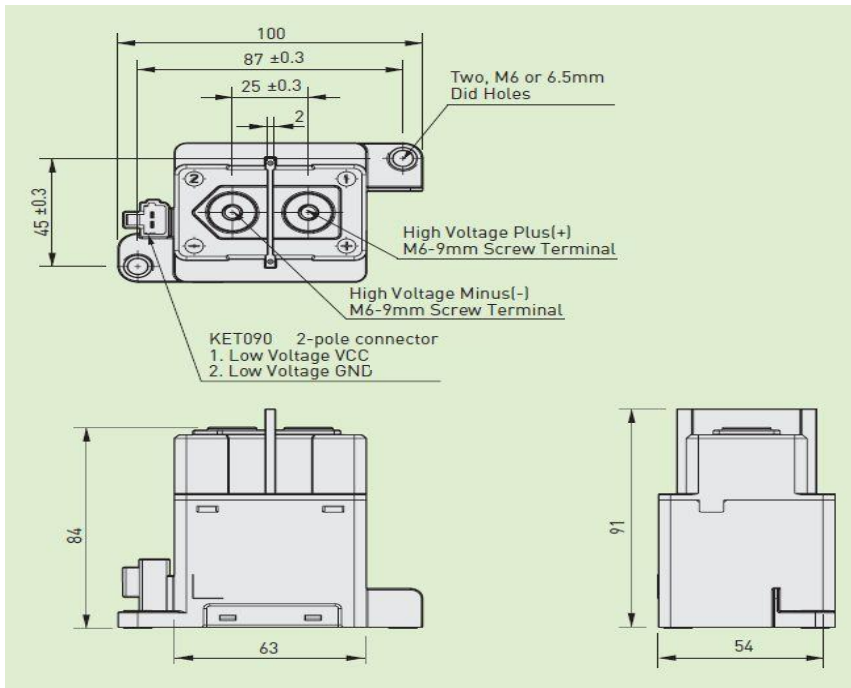

General Tolerance
 Less Than 10: ± 0.25 / 10-50: ± 0.5
 More Than 50: ± 0.8

DC RELAY SPECIFICATIONS			LS ELECTRIC Co.,Ltd
MODEL	GPR-M400	PAGE	4/5

9) Engineering Data

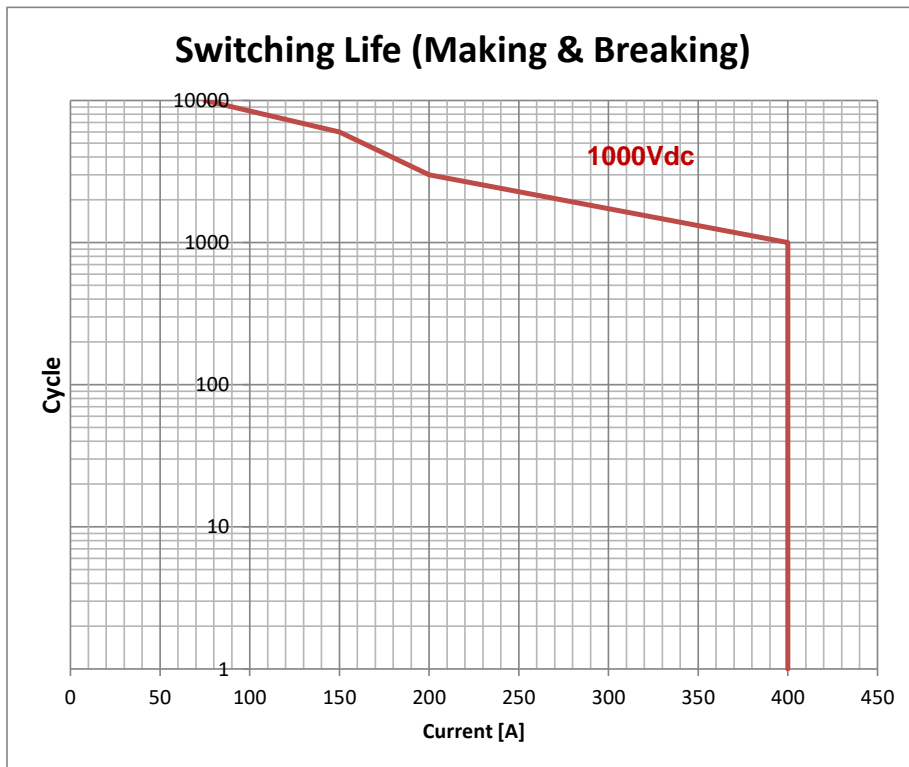
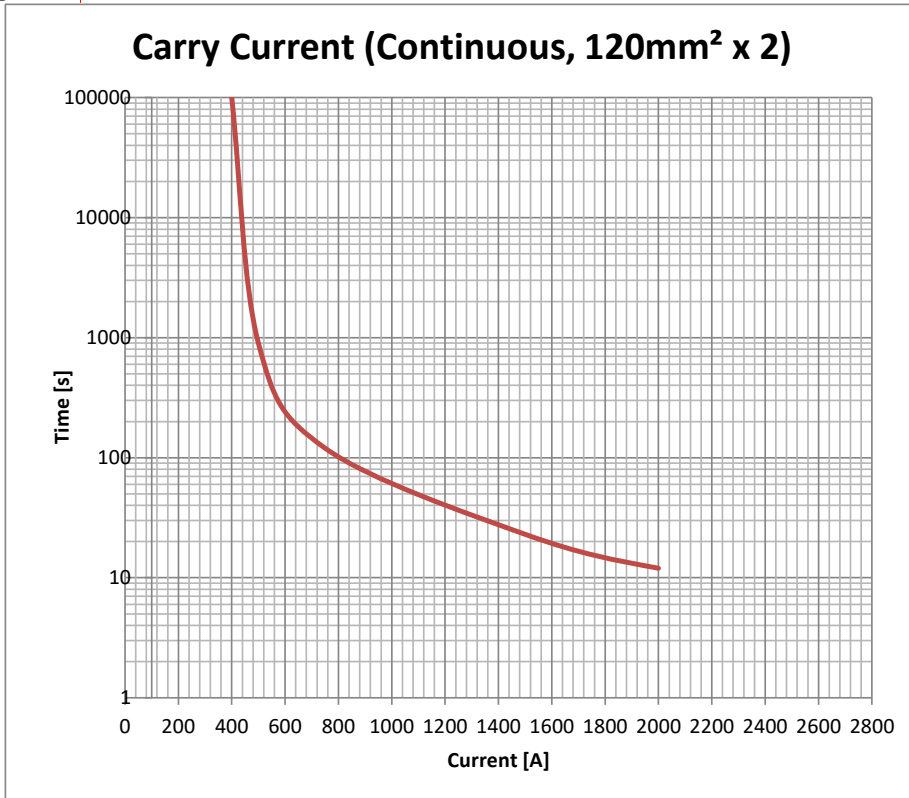

DC RELAY SPECIFICATIONS			LS ELECTRIC Co.,Ltd
MODEL	GPR-M400	PAGE	5/5

10) Cautions For Use

- Please refer to the general catalog for technical terms and specific cautions for use.
- Pick-up and drop-out voltages should be adjusted to the ambient conditions and temperature for the application of your product.
- The repeated turn-off of the coil (during inrush time or in high coil current) when a relay is powered may cause damage to the relay (built-in electric circuit block).
So the coil should not be turned off during the process of inrush.
- Lifetime is specified under the standard test conditions (temperature 15 to 35 , humidity 25 to 86%RH) and is determined according to load type, operation frequency, coil driving circuit, and ambient conditions.
- The relay which is used in the condition exceeding coil rating, contact rating or cycle lifetime may cause overheating.
- The slow escalation of the coil voltage may cause the relay unable to be turned on.
Therefore allow coil the voltage quickly.
- Avoid the cross-connection for it may cause malfunctioning or overheating.
- When the screw and nut are tightened to the fixed relay housing or main circuit terminal, it should be used within the range of torque specified in the catalog.
- If relays are closely mounted or placed close to a heat-generating object, carefully check the abnormal temperature rise and the distance of insulation between the terminals outside the relay, and keep the distance between relays to the minimum of 10mm.
- Avoid the sticking of oil and foreign substances to the main terminal part since this may cause the terminal part to emit unusual heat. Also the tightening torque should be applied as recommended when running branches off from the main terminals.
- Be careful in handling the relay when using or storing it in a high temperature environment since the relay contacts are encapsulated in an inert atmosphere.
- If the nominal voltage and current are continuously applied to the coil and a relay is switched off and then on immediately, the coil temperature will rise, leading to the improvement of the relay coil resistance. This will make the pull-in voltage soar to surpass the nominal value. To avoid such situation, it is recommended to take precautions such as increasing load current, restricting time to apply voltage, applying high coil voltage and then nominal voltage, etc.
- In case of using a capacitive load (C-load), take precautions such as pre-charging to the capacitive load in order to prevent the inrush current from exceeding the rated current
- In case of using an inductive load of L/R 1ms, take precautions such as putting surge absorbers in parallel in order to avoid the shortening of electrical life or mis-contact-related problem
- Use the bus bar or wire appropriate to the specific current. For example, the wire with a narrow diameter does not ensure the maximum allowable rated current to contacts.
- Avoid mounting the relay in strong magnetic fields (near a transformer or magnet) or close to an object that radiates heat.
- If relays are proximately installed each other or installed near highly-magnetized parts such as motor and speaker, the relay may change its operational characteristics or cause malfunction. Therefore, after mounting, check performance in actual operational conditions.
- If a product such as a current sensor is installed near the relay, check performance in actual operational conditions.
- Make sure The power supply is disconnected while wiring
- Do not pull with the force of more than 0.5N when pulling a female connector lead wire on the opposite side.
Do not give any shock to a relay or it may have some trouble.
- This product is not waterproof. If you want to install it in a place where waterproofing is required, please develop a measure to satisfy the requirement.
- Avoid using the product in the environment in which an organic solvent (e.g. alcohol, benzene, or thinner) and a strong alkali (ammonia or caustic soda) can be easily adhered to the product.
- Additional production should not be implemented on the relay housing.